

CHQ MODULES INSTALLATION INSTRUCTIONS



Products Covered: CHQ-DSC (Dual Sounder Controller), CHQ-DRC (Dual Relay Controller) & CHQ-MRC (Mains Relay Controller)

Introduction

The CHQ "Smart-Fix" Range of Modules consists of the following models:

CHQ-DIM(SCI) CHQ-DIM/M(SCI) CHQ-DIM/DIN(SCI)	Dual Input Module	CHQ-DZM(SCI) CHQ-DZM/DIN(SCI)	Dual Zone Monitor
CHQ-DRC(SCI) CHQ-DRC/M(SCI) CHQ-DRC/DIN(SCI)	Dual Relay Controller	CHQ-MRC(SCI) CHQ-MRC/DIN(SCI)	Mains Relay Controller
CHQ-DSC(SCI) CHQ-DSC/M(SCI) CHQ-DSC/DIN(SCI)	Dual Sounder Controller	CHQ-SZM(SCI) CHQ-SZM/M(SCI) CHQ-SZM/DIN(SCI)	Single Zone Monitor

Note: (SCI) indicates all modules feature an integral short-circuit isolator. DIN indicates Module housing is designed to fit standard "Top Hat" DIN Rail.

Components

Standard "Smart-Fix" Modules are supplied as two individual components (see Fig 1 & 2). DIN versions are supplied as one unit (see Fig 3).

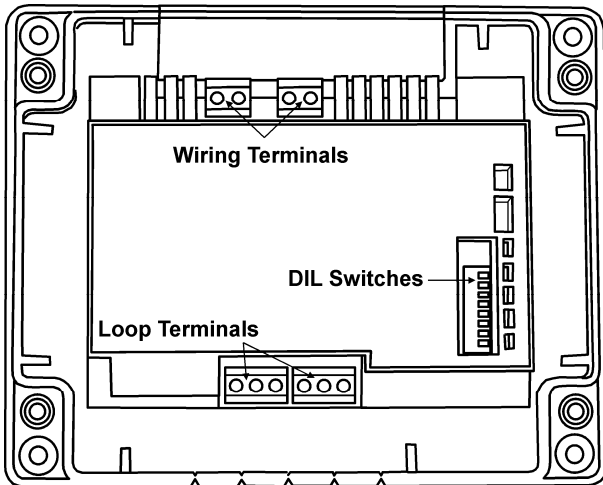

Fig 1

"Smart-Fix" CHQ Module (Back Plate inc PCB Component)

(Note: configuration of Wiring Terminal blocks differs between models)

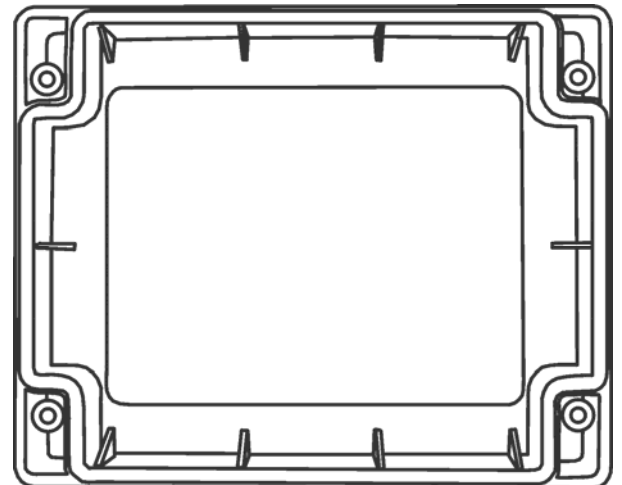

Fig 2

CHQ-LID Transparent Module Lid

(Supplied with four screws and acrylic retaining washers)

Setting the Loop Address

- The analogue address of the Module is set using the first 7 switches of the 8-bit DIL switch, which in the case of the Standard CHQ is located through the cut-out section on the top of the PCB cover. On the DIN version, this switch is located on the edge of the PCB behind the clear door (see Fig 3).

- The switches are numbered 1 to 8 (left to right):

CHQ MODULE	SWITCH UP	ON	
	SWITCH DOWN	OFF	
DIN MODULE	SWITCH UP	OFF	
	SWITCH DOWN	ON	

- The switches should be set using a small-tipped screwdriver or similar.
- Refer to the Address Chart (Fig 7) on page 4 for a quick reference on addresses.

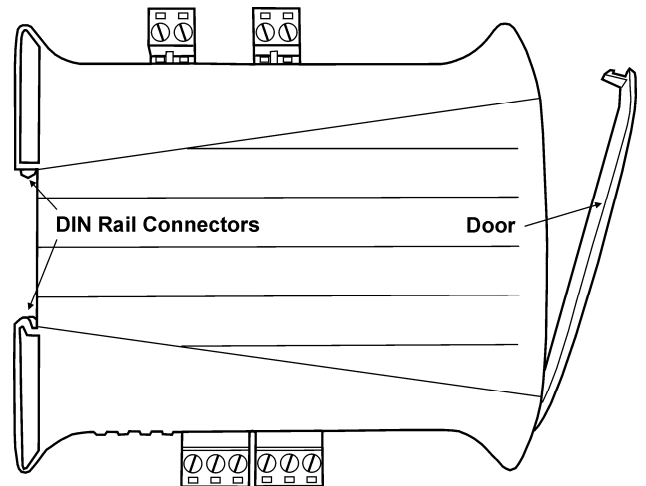
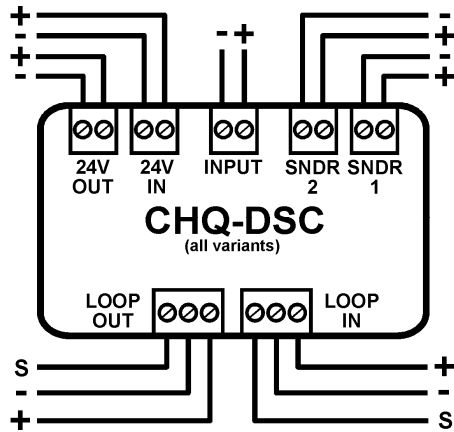

Fig 3

DIN Rail Mountable CHQ

(continued on page 4)

CHQ-DSC DUAL SOUNDER CONTROLLER provides two independent sounder outputs with open and short circuit monitoring (which can be disabled). The sounder outputs can be separately driven, continuously or pulsed, under full synchronisation of the fire alarm panel with other sounders on the same loop. An input is provided with short and open circuit monitoring (which can be disabled).



LOOP CONNECTIONS

S = Cable Screen (if required)
- = Loop Negative (-ve)
+ = Loop Positive (+ve)

Fig 4

Setting Sounder & Input Monitoring

8-Way DIL Switch

CHQ MODULE	SWITCH 8 UP	I/P Monitoring Disabled
	SWITCH 8 DOWN	I/P Monitoring Enabled
DIN MODULE	SWITCH 8 UP	I/P Monitoring Enabled
	SWITCH 8 DOWN	I/P Monitoring Disabled

2-Way DIL Switch

CHQ MODULE	SWITCH 1 UP	SNDR O/P 1 Monitoring Disabled
	SWITCH 1 DOWN	SNDR O/P 1 Monitoring Enabled
	SWITCH 2 UP	SNDR O/P 2 Monitoring Disabled
	SWITCH 2 DOWN	SNDR O/P 2 Monitoring Enabled
DIN MODULE	SWITCH 1 UP	SNDR O/P 1 Monitoring Enabled
	SWITCH 1 DOWN	SNDR O/P 1 Monitoring Disabled
	SWITCH 2 UP	SNDR O/P 2 Monitoring Enabled
	SWITCH 2 DOWN	SNDR O/P 2 Monitoring Disabled

This module requires an auxiliary 24Vd.c. power supply (this can also be monitored) - see Fig 4.

Order codes	CHQ-DSC(SCI) / CHQ-DSC/M(SCI) / CHQ-DSC/DIN(SCI)* ¹		
Transmission method	Digital communications using ESP		
Loop:	Operating voltage	17 - 41 VDC	
	Quiescent current	290 μ A	
	Current consumption whilst polling	22 mA \pm 20 %	
Current in short-circuit	8 mA		
Maximum short-circuit current (Loop)	1 A		
External Supply:-Operating voltage	20-28.8 VDC (24 VDC nominal)		
Current consumption (per line)	Sounder On - 8 mA, Sounder Fault - 6 mA		
Sounder output current	1 A/line max		
Sounder line capacitance	0.3 μ F/line max.		
Sounder E.O.L resistor	1 k Ω , \pm 5%, 2 W		
Input E.O.L resistor	10 k Ω , \pm 5%, 0.25 W		
Input threshold levels	ON=470 Ω , short cct< 50 Ω , open cct>100k Ω ,		
Weights (g) & Dimensions (mm)	CHQ-DSC(SCI)	360	L=157 x W=127 x D=35 (CHQ Module plus Lid) D=79 (CHQ Module plus Lid plus CHQ-BACKBOX) (add 235 to module weight when using CHQ-BACKBOX)
	CHQ-DSC/DIN(SCI)	145	L=119 x W=108 x D=24
Colour and enclosure material	CHQ Module & CHQ-BACKBOX White ABS, DIN Module Green ABS		
* ¹ Fire alarm control panel compatibility required for these products. See AP0127 for short circuit isolator specifications. Note:- All EOL and operational resistors are supplied with the unit – DO NOT DISCARD IN ERROR!			

 Protocol specified in TI/006	CHQ-DRC/(SCI)	0832-CPD-1105	09	EN54-17 Short Circuit Isolators EN54-18 Input/Output Modules
	CHQ-DSC/(SCI)	0832-CPD-1102	09	EN54-17 Short Circuit Isolators EN54-18 Input/Output Modules
	CHQ-DRC/DIN(SCI)	0832-CPD-1107	10	EN54-17 Short Circuit Isolators EN54-18 Input/Output Modules
	CHQ-DSC/DIN(SCI)	0832-CPD-1103	10	EN54-17 Short Circuit Isolators EN54-18 Input/Output Modules

CHQ-DRC DUAL RELAY CONTROLLER is a loop powered input/output module with two independent N/O and N/C volt free change over relay outputs which can be driven separately. Used for the control of devices such as dampers or for plant and equipment shutdown. A single input is also provided for local fire and fault monitoring which is fully monitored for open and short circuit (can be disabled).

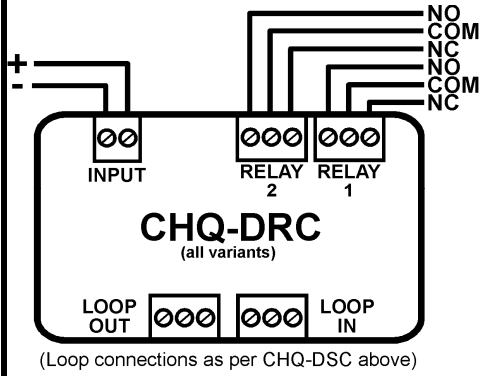

Fig 5

Setting Fault Monitoring

8-Way DIL Switch

CHQ MODULE	SWITCH 8 UP	Monitoring Disabled
	SWITCH 8 DOWN	Monitoring Enabled
DIN MODULE	SWITCH 8 UP	Monitoring Enabled
	SWITCH 8 DOWN	Monitoring Disabled

Note:- The state of the relay contacts will be indeterminate until the unit is powered.

Order codes	CHQ-DRC(SCI) / CHQ-DRC/M(SCI) / CHQ-DRC/DIN(SCI)*		
Transmission method	Digital communication using ESP		
Loop:	Operating voltage	17 - 41 VDC	
	Quiescent current	300 μ A	
	Current consumption whilst polling	22 mA \pm 20 %	
Current in short-circuit	8 mA		
Maximum short-circuit current (Loop)	1 A		
Relay contact rating	30 VDC max, 1 A (resistive load)		
Input E.O.L resistor	10 k Ω , \pm 5%, 0.25 W		
Input threshold level	ON=470 Ω , Short cct <50 Ω , Open cct >100K Ω		
Weights (g) and Dimensions (mm):	CHQ-DRC(SCI)	346	L=157 x W=127 x D=35 (CHQ Module plus Lid) D=79 (CHQ Module plus Lid plus CHQ-BACKBOX) (add 235 to module weight when using CHQ-BACKBOX)
	CHQ-DRC/DIN(SCI)	124	L=119 x W=108 x D=24
Colour and enclosure material	CHQ Module & CHQ-BACKBOX White ABS, DIN Module Green ABS		

* Fire alarm control panel compatibility required for these products. See AP0127 for short circuit isolator specifications.

Note:- All EOL and operational resistors are supplied with the unit – DO NOT DISCARD IN ERROR!

CHQ-MRC MAINS RELAY CONTROLLER is a loop powered input/output module, with a single mains-rated change-over relay output, which has the N/O, N/C and COMMON contacts available via flying leads. This output is driven under the control of the fire alarm panel and can be used for the control of devices such as dampers or for plant and equipment shutdown. A single input is also provided for local fire and fault monitoring and this is fully monitored for open and short circuit (can be disabled). Note:- The state of the relay contacts will be indeterminate until the unit is powered.

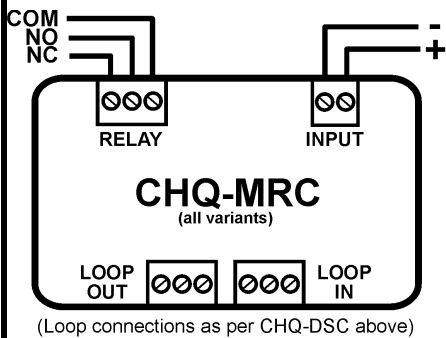

Fig 6

Setting Input Monitoring

8-Way DIL Switch

CHQ MODULE	SWITCH 8 UP	Monitoring Disabled
	SWITCH 8 DOWN	Monitoring Enabled
DIN MODULE	SWITCH 8 UP	Monitoring Enabled
	SWITCH 8 DOWN	Monitoring Disabled

To ensure compliance with EN54-17 and EN54-18 is maintained, the CHQ-MRC/DIN(SCI) shall be installed within an enclosure where the combined weight of the enclosure and the device is greater than 4.75kg, the enclosure shall also have an ingress protection rating of IP65 or greater.

Order codes	CHQ-MRC(SCI) / CHQ-MRC/DIN(SCI)*		
Transmission method	Digital communication using ESP		
Loop:	Operating voltage	17 - 41 VDC	
	Quiescent current	300 μ A	
	Current consumption whilst polling	22 mA \pm 20 %	
Relay contact rating	48 VDC max, 2 A (resistive load), 250 VAC max, 5 A (resistive load) – mains AC switching should only be on the same phase as the control panel.		
Input E.O.L resistor	10 k Ω , \pm 5%, 0.25 W		
Input threshold level	ON=470 Ω , Short cct <50 Ω , Open cct >100 K Ω		
Weights (g) and Dimensions (mm)	CHQ-MRC(SCI)	331	L=157 x W=127 x D=35 (CHQ Module plus Lid) D=79 (CHQ Module plus Lid plus CHQ-BACKBOX) (add 235 to module weight when using CHQ-BACKBOX)
	CHQ-MRC/DIN(SCI)	121	L=119 x W=108 x D=24
Colour and enclosure material	CHQ Module & CHQ-BACKBOX White ABS, DIN Module Green ABS		

* Fire alarm control panel compatibility required for these products. See AP0127 for short circuit isolator specifications.

Note:- All EOL and operational resistors are supplied with the unit – DO NOT DISCARD IN ERROR!

Installation – "Smart-Fix" Version

- ❑ Set analogue address before installation (see page 1). The fixing surface should be dry and stable.
- ❑ Hold the back plate up against the fixing surface and mark the position of the four corner fixing holes.
- ❑ Determine which cut-out sections along the top and bottom edges of the module require removing to accommodate the cables being used.
- ❑ Remove cut-outs by scoring with a sharp knife before breaking off with pliers or snips.
- ❑ Mount the back plate using appropriate fixings (not supplied) for the fixing surface.
- ❑ Terminate and connect field wiring as per the wiring diagrams on pages 2 & 3 (and the terminal block indications on the product label).

The transparent lid (CHQ-LID) is supplied with four screws and eight retaining washers.

- ❑ Push the screws through one of the retaining washers and then through the holes in the lid from front to back, pushing another retaining washer onto the end inside the lid.
- ❑ Screw the lid onto the back plate; do not over tighten the screws as this could damage the unit.

NOTE: A white plastic version of the lid is available (sold separately – CHQ-LID(WHT)).

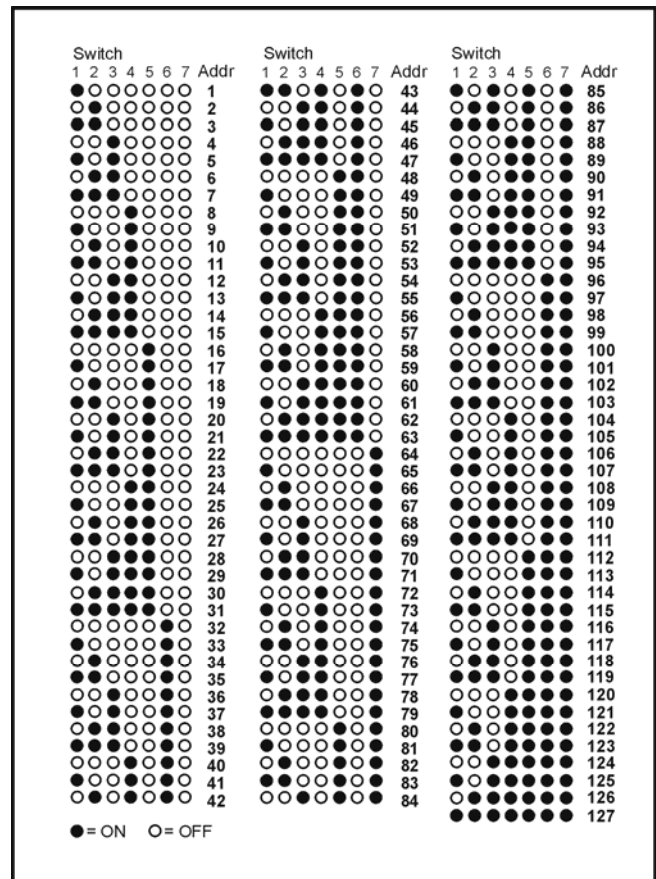

Fig 7

Installation – "Smart-Fix" with Back Box

For those installations requiring glanded cables, a module back box (CHQ-BACKBOX) is available (sold separately). This features ten knock-out cable entries (glands are not supplied). Ensure glands used conform to IP67, if such ingress protection is required. The CHQ-BACKBOX is mounted on the fixing surface; the CHQ Module is then fitted to the top of the back box. Finally the CHQ-LID is added creating a sealed enclosure. For further details refer to the CHQ-BACKBOX Instructions (2-3-0-800).

Installation – DIN Version

Set analogue address before installation (see page 1) and write loop address in space provided on door label.

- ❑ DIN modules should be mounted in a suitable enclosure in conjunction with an NS 35 mounting rail with the loop connections at the bottom of the unit. Hochiki recommends the SMB-2 and SMB-3 Boxes designed specifically for this purpose.
- ❑ Terminate and connect field wiring as per the wiring diagrams on pages 2 & 3 (and the terminal block indications on the product label).
- ❑ Suitable anti-static precautions must be taken when handling these products.

Status LEDs

Refer to the following table for Status LED indications:

CHQ-DRC (all variants)	Dual Relay Controller	Green LED flashes each time the unit is polled by the fire alarm control panel.
CHQ-MRC (all variants)	Mains Relay Controller	Amber LED is continually illuminated when unit detects short-circuit fault.
CHQ-DSC (all variants)	Dual Sounder Controller	Green LED flashes each time the unit is polled by the fire alarm control panel and a red LED is continuously illuminated when either output is active. Amber LED is continually illuminated when unit detects short-circuit fault.



Hochiki Europe (UK) Ltd
 Grosvenor Road, Gillingham Business Park,
 Gillingham, Kent, ME8 0SA, England
 Telephone: +44(0)1634 260133
 Facsimile: +44(0)1634 260132
 Email: sales@hochikieurope.com
 Web: www.hochikieurope.com

Hochiki Europe (UK) Ltd. reserves the right to alter the specification of its products from time to time without notice. Although every effort has been made to ensure the accuracy of the information contained within this document it is not warranted or represented by Hochiki Europe (UK) Ltd. to be a complete and up-to-date description. Please check our web site for the latest version of this document.